

Small Space LED Luminaire

Product Data Sheet

Our motion sensing Small Space LED Luminaire provides unparalleled performance, improved efficacy, more usable lumens per watt. This is the reliable and sustainable LED lighting solution for small areas that will automatically energize when motion is detected up to 20-feet away.

Benefits

- Meets the requirements of the 2023 National Electrical Code: Articles 410.16(A)(B)(1)(3), (D)(1)(3), 410.52, and 410.80(A)(B).
- ETL Listed to UL 1598 Standards.
- For New or Retrofit applications.
- Significant energy savings.
- Energy efficient and optimized light output.
- Cost-effective, eliminates batteries, and saves money.
- Suitable for indoor applications only.
- Suitable for installation applications in small spaces or closets.
- Prescriptive rebates may be available from electric utilities or co-ops.
- Complies with general rebate requirements for lighting upgrades.
- Five (5) year warranty.

Features

- Designed for ceiling mount applications.
- The luminaire automatically lights when occupancy is detected; turns off after a three (3) minute vacancy.
- Operates on 120V line voltage.
- Corrosion resistant housing.
- Small form factor.

Specifications

- **Output Lumens:** 1,050 Lumens
- **Correlated Color Temperature (CCT):** 3000K, 4000K, or 5000K
- **Power Factor:** 0.9 Minimum
- **Operating Voltage:** 120-Volts
- **Power Consumption:** 15-Watts
- **Amperes:** .15 Amps
- **Color Rendering Index (CRI):** 80 Minimum
- **Efficacy:** 70 lm/W
- **Applications:** Dry Environments Only
- **Locations:** Ceiling Mount
- **Operating Temperature:** 32°F (0°C) to 104°F (40°C)
- **Diffuser:** Twist-On, Frosted Acrylic
- **Motion Sensing Range:** Up to 20 Feet Dia.
- **Dimmable:** No
- **Warranty:** 5 Years
- **Materials:** Steel (Heat Sink) and Plastic
- **Power Conductors:** 3-Wire (Black, White, Bare Ground)
- **Sensor Type:** Passive Infrared Sensor (PIR)
- **Switch:** No Switch
- **Certifications:** ETL Listed to UL 1598 Standards, Energy Star Certified.



Small Space LED Luminaire
Part Number:
16560



Color Select Options

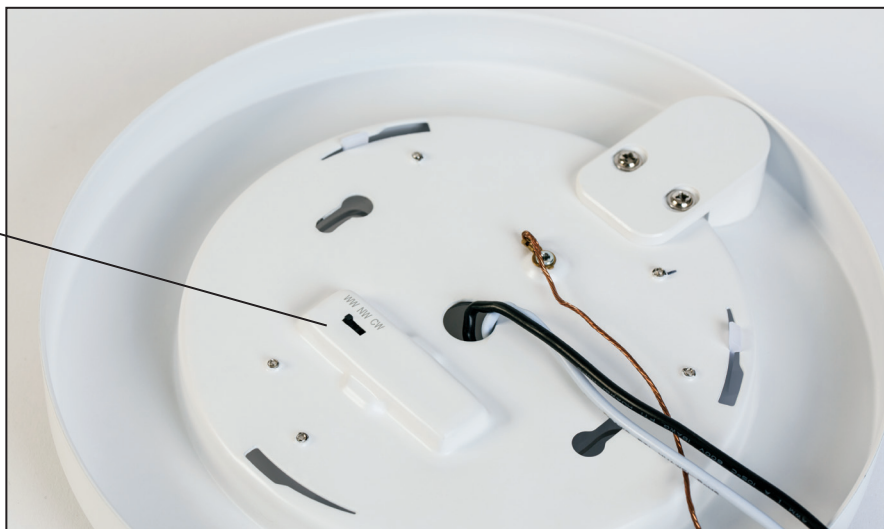

Warm White
3000K



Bright White
4000K



Cool White
5000K

Dimensions

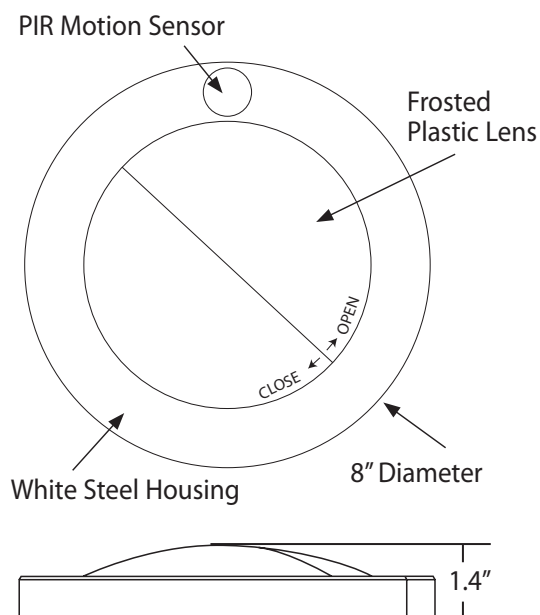

Motion Sensor Range

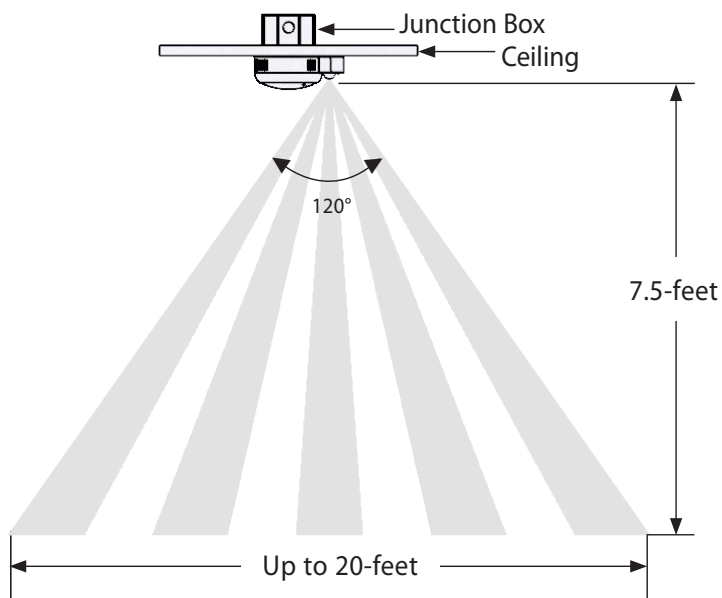

Catalog Number	UPC Number	Description	Order Unit	Unit Qty	Unit Pkg	Units/ Case	TL Case Qty	Min Order Qty	MM Req	Ship Wt (Lbs)
16560	16560	Small Space LED Luminaire	EA	1	BX	20	20	1	No	2

UNITS OF MEASURE KEY

Order Unit: The Unit to be ordered; **Order Qty:** Number of pieces in each Unit; **Unit Pkg:** Packaging types - BG (Bag), BX (Box), BRL (Barrel); **Units/ Case:** Unit packages contained in the Case; **TL Case Qty:** The total number of items in each Master Case; **Min Order Qty:** The smallest Unit that can be ordered; **MM Req:** Must order multiples of the Unit in the stated quantities; **Ship Wt (Lbs):** Total weight of the units per Carton

E02-150-047 (02/23 - AJ)
© 2023 Engineered Products Company. All Rights Reserved.

